

Actuators

Two Piston
Pneumatic



USA operations

www.tfvusao.com

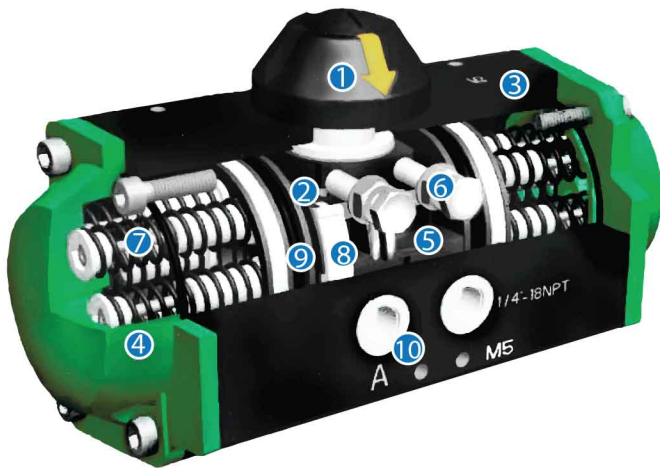

1. Indicator

Indicator according to VID/VIE3845 is convenient for mounting accessories such as limit switch box, Positioner and etc.

2. Pinion

The design of the nickel-plated alloy steel integrated forging pinion drive is according the NAMUR,ISO5211 and DIN3337 standards. Special standard are available upon request.

3. Actuator Body

High quality aluminum alloy extrusion formed. The surface has been treated by anodized hardening followed by epoxy polyester coating. Other surface treatments are available e.g. PTFE and Nickel plating as well as other colour coatings on request.

4. End Cap

The surface has been treated by anodized hardening followed by epoxy polyester coating. Other surface treatments are available on request e.g. PTFE and Nickel plating as well as other colours on request.

5. Piston

Manufactured from Die-cast aluminum and treated by anodized hardening process. Symmetric mounting of the piston helps to ensure easy maintenance. Reverse action requirements can be achieved by inverting the pistons.

6. Adjusting Bolt

The two independent adjustment bolts can adjust opening and closing of the mounted valve within $\pm 5^\circ$.

7. Spring

Preloaded high grade springs with surface epoxy resin painted, which can be demounted conveniently to satisfy different requirements of torque by changing quantity of springs.

8. Piston Ring

Manufactured from low friction long life material POM. Can be easily changed for maintenance purposes.

9. O-rings

Standard NBR rubber O-rings provide trouble-free operation at standard temperature ranges. For other temperature requirements relevant materials can be offered on request.

10. Air Connection

Conforms to NAMUR standards

11. All stop parts are manufactured from SS304.

Operations

The standard rotation is clockwise to close; counter-clockwise rotation is obtained when port A is pressurized.

Double Acting Operation Function (Standard Rotation) Top View

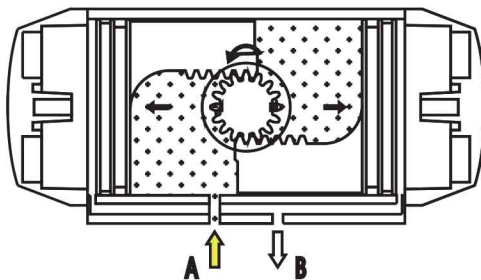

Air supplied to Port A forces the pistons apart and toward end positions, with exhaust air exiting at Port B, a counter-clockwise rotation is obtained.

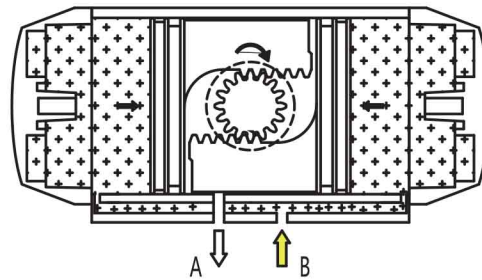

Air supplied to Port B forces the pistons together with exhaust air exiting at Port A, a clockwise rotation is obtained.

Single Acting Operation Function (Standard Rotation) Top View

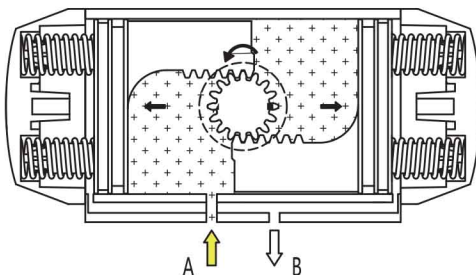

Air supplied to Port A forces the pistons apart and toward end positions, compressing the springs with exhaust air exiting at Port B, a counter-clockwise rotation is obtained.

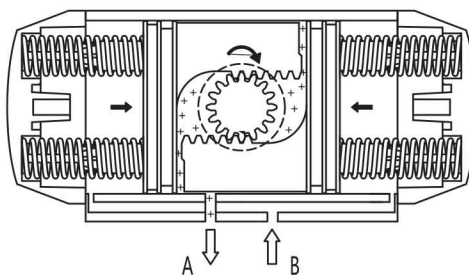

On loss of air pressure (air or electric failure) at port A allows the springs to force the pistons to the centre position with exhaust air exiting at Port A, a clockwise rotation is obtained.

EXPLODE VIEW

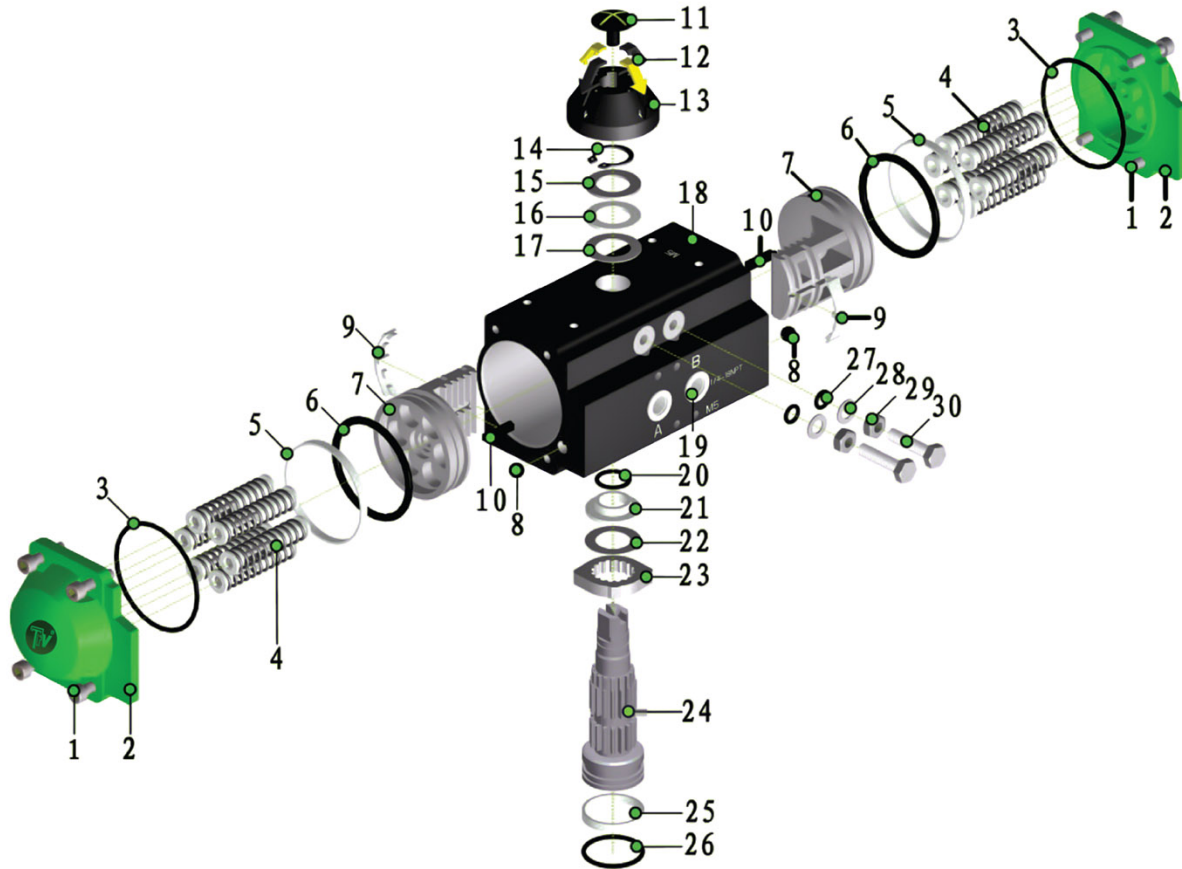

2



Compared with the ordinary actuators, we drill four extra thread holes on the bottom of actuator. Using our connecting plates, it can be connected with all kinds of international standard valve flanges fairly.

The large diameter hole of the output pinion on the bottom makes our actuator suitable for all kinds of valve stems and connecting keys by using our insert. Efficient and economic.

Extra deep hole for pinion shaft on the bottom of actuator is suitable for any long size v valve stem.

PARTS LISTS

No	Part Description	QTY	Materials	Surface Treated	Optional Material
1	Socket Head Screw	8	SUS 304		
2	End Cap	2	AL ≤ ARP1165 WCB ≥ ARP1970	Anode Hardening +Polyester Coating	CF8/CF8M
3	"O" ring (Cylinder Head)	2	NBR Rubber		Viton/Silicone Rubber
4	Spring	2	Spring Steel	Epoxy resin Coating	
5	Piston Ring	2	POM		
6	"O" ring (Piston)	2	NBR Rubber		Viton/Silicone Rubber
7	Piston	2	AL380	Anode Hardening	
8	Stopper	2	NBR Rubber		
9	Guide Ring	2	PA6		
10	Guide Block	1	PA6		
11	Indicator Bolt	4	ABS		
12	Indicator Arrowhead	1	ABS		
13	Indicator	1	ABS		
14	Snap Ring	1	Stainless Steel		
15	Washer	1	SUS 304		
16	Disc Bearing	1	POM		
17	Washer	1	SUS 304		
18	Body	2	AL 6063-T6	Anode Hardening +Polyester Coating	CF8/CF8M
19	Plug	1	PVC		
20	"O" ring (Pinion Top)	1	NBR Rubber		Viton/Silicone Rubber
21	Bearing (pinion Top)	1	POM		
22	Disc Bearing	1	SUS 304		
23	Stroke Adjustment Stop	1	SAE 1020	Nickel Plated	CF8/CF8M
24	Pinion Shaft	1	SAE 1045	Nickel Plated	SUS304/SUS316
25	Bearing (Pinion Bottom)	1	POM		
26	"O" ring (pinion bottom)	2	NBR Rubber		Viton/Silicone Rubber
27	"O" ring (Adjusting Bolt)	2	NBR Rubber		Viton/Silicone Rubber
28	Metal Washer	2	SUS 304		
29	Nut	2	SUS 304		
30	Adjusting Bolt	2	SUS 304		

INSTALLATION SIZE (ARP0006-ARP9210)

4

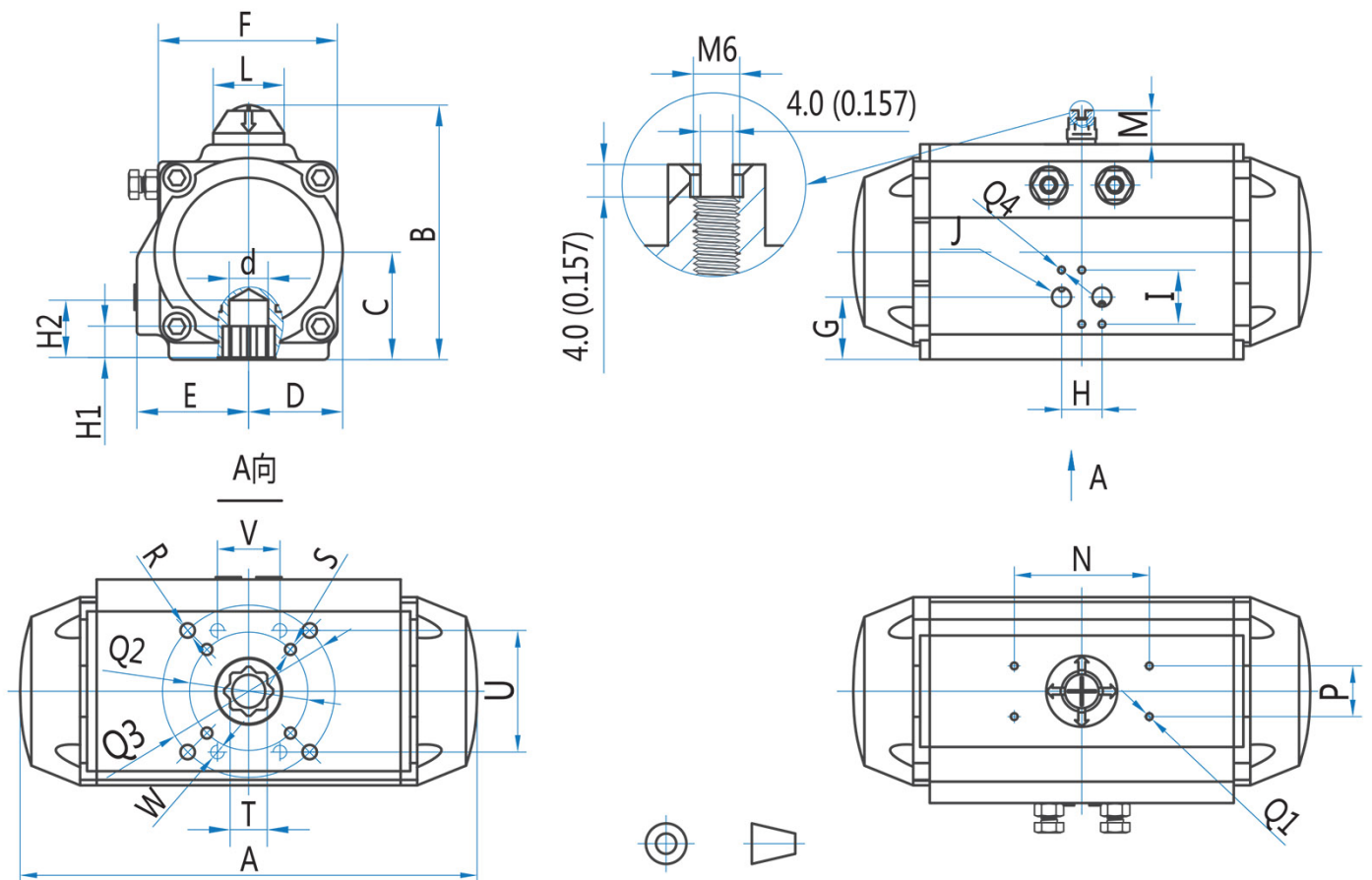

Imperial Unit Inch

Model Size	ARP0006	ARP0010	ARP0017	ARP0031	ARP0063	ARP0098	ARP0142	ARP0236	ARP0300	ARP0462	ARP0625	ARP0848	ARP1165	ARP1970	ARP3200	ARP4025	ARP5876	ARP9210
A	3.23	4.29	5.83	6.26	8.39	9.80	10.67	12.40	13.62	16.22	17.44	19.37	21.54	24.17	28.70	33.03	35.43	45.59
B	2.83	2.95	3.58	4.21	4.88	5.43	5.87	6.89	7.48	8.27	9.06	10.00	10.91	13.62	15.28	16.06	18.11	20.35
C	1.22	1.10	1.34	1.65	2.01	2.28	2.52	2.87	3.11	3.46	3.86	4.33	4.80	5.75	6.57	7.01	8.07	9.21
D	0.81	1.06	1.14	1.42	1.73	1.93	2.20	2.52	2.72	3.15	3.46	3.90	4.29	5.16	5.79	6.38	7.44	10.24
E	1.18	1.30	1.61	1.85	2.09	2.24	2.60	3.03	3.23	3.62	3.86	4.17	4.41	5.16	5.79	6.81	7.68	10.24
F	1.99	2.36	2.09	2.60	3.23	3.62	4.17	4.76	5.12	5.87	6.30	7.09	7.80	9.09	10.00	11.42	13.23	13.03
G	1.02	1.10	1.02	1.18	1.14	1.26	1.46	1.46	1.81	2.09	2.05	2.36	2.60	2.76	3.54	3.35	3.62	9.17
H	0.94	0.94	0.94	0.94	0.94	0.94	0.94	0.94	0.94	0.94	0.94	0.94	0.94	1.57	1.57	1.57	1.57	1.57
I	1.26	1.26	1.26	1.26	1.26	1.26	1.26	1.26	1.26	1.26	1.26	1.26	1.26	1.77	1.77	1.77	1.77	1.77
1	NPT1/8"	NPT1/8"	NPT1/4"	NPT1/4"	NPT1/4"	NPT1/4"	NPT1/4"	NPT1/4"	NPT1/4"	NPT1/4"	NPT1/4"	NPT1/4"	NPT1/4"	NPT3/8"	NPT3/8"	NPT1/2"	NPT1/2"	NPT1/2"
L	φ1.18	φ1.18	φ1.57	φ1.57	φ1.57	φ1.57	φ1.57	φ2.36	φ2.36	φ2.36	φ2.36	φ3.15	φ3.15	φ3.15	φ3.15	φ3.15	φ2.95	φ2.95
M	0.79	0.79	0.79	0.79	0.79	0.79	0.79	1.18	1.18	1.18	1.18	1.18	1.18	1.97	1.97	1.97	1.97	1.97
N	1.00	1.61	3.15	3.15	3.15	3.15	3.15	3.15	3.15	3.15	3.15	5.12	5.12	5.12	5.12	5.12	5.12	5.12
P	1.00	1.18	1.18	1.18	1.18	1.18	1.18	1.18	1.18	1.18	1.18	1.18	1.18	1.18	1.18	1.18	1.18	1.18
Q1	M5	M5	M5	M5	M5	M5	M5	M5	M5	M5	M5	M5	M5	M5	M5	M5	M5	M5
Q2	φ1.42 (36)	φ1.42 (36)	φ1.65 (50)	φ1.97 (50)	φ1.97 (50)	φ1.97 (50)	φ2.76 (70)	φ2.76 (70)	φ4.02 (102)	φ4.02 (102)	φ4.02 (102)	φ4.02 (102)	φ4.02 (102)	φ4.92 (125)	-	-	-	-
Q3	-	φ1.65 (50)	-	-	φ2.76 (70)	φ2.76 (70)	φ4.02 (102)	φ4.02 (102)	-	φ4.92 (125)	φ4.92 (125)	φ5.51 (140)	φ5.51 (140)	φ6.50 (165)	φ6.50 (165)	φ6.50 (165)	φ10 (254)	φ10 (254)
Q4	M5	M5	M5	M5	M5	M5	M5	M5	M5	M5	M5	M5	M5	M6	M6	M6	M6	M6
R	-	4-M6	-	-	4-M8	4-M8	4-M10	4-M10	-	4-M12	4-M12	4-M16	4-M16	4-M20	4-M20	4-M20	8-M16	8-M16
S	4-M5	4-M5	4-M5	4-M6	4-M6	4-M6	4-M8	4-M8	4-M10	4-M10	4-M10	4-M10	4-M10	4-M12	-	-	-	-
T	0.35 (9)	0.35 (9)	0.67 (17)	0.67 (17)	0.87 (22)	0.87 (22)	0.87 (22)	0.87 (22)	1.42 (36)	1.42 (36)	1.42 (36)	1.42 (36)	1.42 (36)	1.81 (46)	1.81 (46)	1.81 (46)	2.17 (55)	2.17 (55)
H1	0.43	0.43	0.47	0.63	0.75	0.75	0.91	0.91	1.14	1.14	1.14	1.65	1.65	1.97	1.97	1.97	2.36	2.36
d	-	-	φ 0.56	φ 0.56	φ 0.77	φ 0.77	φ 0.91	φ 0.91	φ 1.42	φ 1.42	φ 1.42	φ 1.50	φ 1.50	φ 1.89	φ 1.89	φ 1.89	φ 2.17	φ 2.17
H2	-	-	1.26	1.34	1.34	1.34	1.89	1.89	2.56	2.56	2.56	3.62	3.62	3.62	3.62	3.62	3.94	3.94
U	-	-	-	-	-	-	2.83	2.83	2.83	2.83	2.83	3.90	3.90	-	-	-	-	-
V	-	-	-	-	-	-	1.46	1.46	1.46	1.46	1.46	2.09	2.09	-	-	-	-	-
W	-	-	-	-	-	-	M8	M8	M8	M8	M8	M10	M10	-	-	-	-	-

- 1.-Top mounting connection is in line with VDI/VDE3845 standards, permitting direct installation of accessories such as positioner or limit switch box.
- 2.-Bottom mounting connection is in line with ISO5211 and DIN3337 standards.
- 3.-Air supply connection is in line with VDI/VDE3845 and NAMUR standards, and can install solenoid valves conveniently

Weight & Air Consumption

Imperial Unit Inch

Data	Body Diameter			Opening Time DA	Closing Time DA	Approximate Weight-DA
Model	φ (In)	CCW (L)	CW (L)	S (sec.)	S (sec.)	lb
ARP0006	1.26	0.015	0.034	0.13	0.14	0.71
ARP0010	1.57	0.032	0.068	0.14	0.16	1.53
ARP0017	1.97	0.08	0.13	0.17	0.19	2.38
ARP0031	2.48	0.15	0.25	0.19	0.22	3.42
ARP0063	2.95	0.3	0.48	0.23	0.27	6.06
ARP0098	3.46	0.5	0.73	0.33	0.35	8.33
ARP0142	3.94	0.75	1.08	0.42	0.48	11.68
ARP236	4.53	1.19	1.8	0.72	0.93	18.5
ARP0300	4.92	1.55	2.18	0.84	1.09	21.89
ARP0462	5.71	2.40	3.55	1.32	1.42	31.08
ARP0625	6.3	3.20	4.72	1.6	2.0	40.45
ARP0848	7.09	4.30	6.80	2	2.4	55.12
ARP1165	7.87	5.87	9.53	2.7	3.5	77.16
ARP1970	9.45	10	15	3.5	4.5	138.89
ARP3200	10.63	15	23	4.5	5.0	174.16
ARP4025	11.81	21.1	30.5	8.8	12.7	299.39
ARP5876	13.78	30.8	44.4	13	19	516.54
ARP9210	15.75	48.3	69.6	20	29	745.16

*The above indicated moving time of the actuator, are obtained in the following testcons:

- | | |
|---|---|
| <ul style="list-style-type: none"> (1)Room temperature (2)Actuator stroke 90° (3)Solenoid valve with orifice of 4mm and flow capacity QN 400L/min. | <ul style="list-style-type: none"> (4)Inside pipe diameter 5mm (5)Medium clean air (6)Air supply pressure 5.5 bar (79.75psi) (7)Actuator without external resistance load |
|---|---|



Output Torque of Double Acting Actuator (inch)

Imperial unit in-lb:

Air pressure Model	40PSI	60PSI	70PSI	80PSI	90PSI	100PSI	120PSI
ARP0006D	26	41	51	59	67	76	92
ARP0010D	41	64	77	89	101	113	137
ARP0017D	77	110	135	155	174	201	243
ARP0031D	130	197	245	275	311	340	421
ARP0063D	277	430	500	559	632	702	833
ARP0098D	431	641	752	870	970	1081	1328
ARP0142D	623	952	1085	1261	1419	1604	1959
ARP0236D	1050	1556	1837	2095	2362	2625	3149
ARP0300D	1327	1923	2289	2664	3003	3357	4047
ARP0462D	1872	2884	3588	4102	4614	5145	6317
ARP0625D	2849	4120	4784	5549	6180	6871	8331
ARP0848D	3622	5557	6492	7529	8331	9278	11325
ARP1165D	5087	7690	9037	10344	11536	12748	15390
ARP1970D	8709	13138	15248	17492	19684	21869	26230
ARP3200D	14203	21240	24772	28413	32044	35577	42755
ARP4025D	17865	26798	31443	35738	40201	44663	53595
ARP5876D	26086	39130	45862	52173	58695	65215	78251
ARP9210D	40891	61322	71881	81775	91993	102213	122654

Output Torque of Spring Return Actuator(inch)

Imperial unit in-lb:

Size	Output Torque of Spring Return Actuator(inch)															Spring	Return
	Spring Quantity	40PSI		60PSI		70PSI		80PSI		90PSI		100PSI		120PSI		0°	90°
		0°	90°	0°	90°	0°	90°	0°	90°	0°	90°	0°	90°	0°	90°		
ARP0010S	2					51	33	62	45	73	56	87	69	110	93	27	44
	4									55	21	70	34	92	58	44	80
ARP0017S	5	53	39	82	67	109	95	129	114	146	131	174	160	215	200	27	42
	6	46	31	75	58	103	86	122	105	139	122	167	151	208	190	34	50
	7	41	23	69	49	97	78	115	96	133	113	161	142	201	181	40	59
	8			61	38	90	68	108	86	125	103	154	133	194	171	47	69
	9			55	30	84	61	102	78	119	94	148	125	188	163	53	77
	10					78	53	96	70	113	86	142	117	181	155	59	85
	11					71	44	89	60	105	76	135	107	174	145	66	95
	12					64	34	82	51	98	66	128	98	167	135	73	104
ARP0031S	5	84	60	145	118	197	172	225	199	259	233	290	265	369	342	50	76
	6	75	46	135	102	187	156	215	183	249	216	281	249	359	326	60	92
	7	66	31	114	85	178	141	205	167	239	200	271	234	349	309	70	108
	8			103	70	167	127	194	153	228	185	261	220	338	295	81	122
	9			92	54	157	112	184	137	217	168	250	204	327	278	91	138
	10				38	147	97	173	121	206	152	240	188	316	262	102	154
	11					138	81	163	105	196	135	230	173	306	245	112	170
	12					128	67	154	90	186	120	221	158	296	230	121	185
ARP0063S	5	183	130	325	266	402	346	457	399	526	467	602	545	728	668	102	159
	6	167	102	307	233	385	316	439	168	508	435	584	514	710	636	119	190
	7	149	73	287	201	366	286	420	337	488	403	565	484	689	604	139	221
	8			266	169	346	256	399	306	467	371	545	453	668	572	159	252
	9			246	137	328	226	381	275	448	339	527	423	649	540	178	283
	10			226	105	309	197	361	244	428	307	507	392	629	508	197	314
	11					291	167	342	213	407	275	488	362	609	476	217	345
	12					272	137	322	182	387	243	469	331	589	444	236	376
ARP0098S	5	278	187	469	366	591	496	703	604	798	696	917	820	1155	1053	166	266
	6	248	140	435	313	560	446	670	552	764	643	885	769	1122	1000	199	317
	7	218	93	401	260	528	396	637	501	731	590	853	718	1088	947	232	368
	8			368	207	497	347	605	449	698	536	821	668	1055	894	264	419
	9			335	154	467	297	574	398	665	483	790	617	1022	840	296	471
	10			301	101	435	248	541	346	631	430	758	567	988	787	328	522
	11					403	198	508	295	597	377	725	516	954	734	361	573
	12					372	149	475	243	563	324	693	466	920	681	394	625
ARP0142S	5	418	305	722	595	871	752	1038	914	1189	1062	1385	1264	1729	1602	222	345
	6	377	241	676	523	827	684	993	844	1143	990	1341	1195	1683	1530	267	415
	7	335	177	629	450	784	617	947	774	1096	917	1297	1127	1636	1458	312	485
	8			582	378	740	549	902	704	1049	845	1252	1058	1589	1385	358	555
	9			536	306	696	482	857	634	1002	773	1208	989	1543	1313	403	625
	10			490	234	654	415	812	565	957	701	1164	921	1497	1241	447	694
	11					610	348	767	494	910	629	1120	852	1450	1169	492	764
	12					566	280	721	424	862	557	1074	783	1403	1097	538	834

Output Torque of Spring Return Actuator (inch)

Imperial unit in-lb:

Size Model	Spring Quantity	Output Torque of Spring Return Actuator (inch)														Spring 0°	Return 90°
		40PSI		60PSI		70PSI		80PSI		90PSI		100PSI		120PSI			
		0°	90°	0°	90°	0°	90°	0°	90°	0°	90°	0°	90°	0°	90°		
ARP0236S	5	716	513	1199	970	1487	1273	1731	1509	1987	1758	2267	2049	2774	2554	363	584
	6	651	407	1126	851	1418	1162	1660	1403	1913	1648	2197	1936	2701	2435	434	699
	7	586	301	1053	732	1350	1051	1589	1287	1831	1520	2127	1822	2628	2307	504	814
	8			970	613	1273	940	1518	1172	1758	1401	2049	1709	2554	2188	584	929
	9			897	494	1205	829	1447	1048	1685	1282	1979	1596	2472	2069	655	1044
	10					1136	718	1367	932	1611	1163	1910	1482	2399	1950	726	1159
	11					1068	607	1296	817	1538	1044	1840	1369	2325	1831	797	1274
	12							1225	701	1456	925	1761	1256	2243	1712	867	1389
ARP0300S	5	911	667	1456	1181	1854	1598	2211	1944	2536	2261	2912	2651	3580	3305	451	717
	6	826	529	1360	1025	1765	1453	2117	1793	2440	2106	2821	2502	3484	3149	544	867
	7	741	399	1263	879	1675	1316	2024	1651	2344	1959	2729	2363	3387	3003	637	1009
	8			1163	723	1581	1171	1926	1500	2243	1804	2633	2215	3287	2847	735	1159
	9			1067	568	1491	1025	1833	1349	2147	1648	2542	2066	3191	2692	827	1310
	10					1401	880	1740	1198	2051	1492	2450	1918	3094	2536	920	1460
	11					1312	743	1647	1056	1955	1346	2359	1779	2998	2390	1013	1602
	12					1218	598	1549	906	1854	1190	2263	1630	2898	2234	1111	1752
ARP0462S	5	1213	838	2142	1721	2897	2504	3382	2974	3897	3490	4438	4037	5576	5154	717	1124
	6	1074	627	1987	1483	2751	2281	3231	2743	3747	3260	4290	3810	5420	4916	867	1354
	7	936	415	1831	1245	2606	2059	3081	2512	3597	3030	4142	3584	5264	4678	1018	1584
	8			1685	1007	2469	1837	2939	2282	3455	2800	4002	3357	5118	4440	1159	1814
	9			1529	778	2324	1624	2788	2060	3304	2579	3854	3139	4962	4211	1310	2036
	10			1373	540	2179	1401	2637	1829	3154	2349	3706	2912	4806	3973	1460	2266
	11					2042	1179	2495	1598	3012	2119	3566	2686	4660	3735	1602	2496
	12					1905	957	2353	1367	2871	1888	3427	2459	4514	3497	1743	2726
ARP0625S	5	1953	1506	3113	2609	3845	3375	4572	4084	5173	4669	5912	5432	7324	6821	974	1460
	6	1766	1237	2902	2307	3649	3093	4368	3791	4962	4367	5711	5144	7114	6518	1177	1752
	7	1579	960	2692	1996	3452	2803	4164	3489	4752	4056	5511	4848	6903	6207	1381	2053
	8			2481	1694	3256	2521	3959	3196	4541	3754	5310	4560	6692	5905	1584	2345
	9			2280	1328	3068	2230	3764	2894	4340	3442	5118	4264	6491	5594	1779	2646
	10			2069	1080	2871	1948	3560	2601	4129	3140	4918	3976	6280	5292	1982	2938
	11					2675	1658	3365	2299	3918	2829	4717	3680	6070	4980	2186	3239
	12					2487	1376	3160	2006	3717	2527	4525	3392	5868	4678	2381	3531
ARP0848S 180	5	2352	1676	5713	4779	5161	4452	6143	5407	6903	6143	7917	7193	9897	9137	1381	2115
	6	2091	1294	5328	4202	4888	4050	5859	4989	6610	5713	7638	6784	9604	8707	1664	2531
	7	1831	911	4944	3625	4614	3649	5575	4572	6317	5283	7359	6374	9311	8276	1947	2947
	8			4559	3058	4341	3238	5291	4146	6024	4843	7080	5955	9018	7837	2230	3372
	9			4166	2490	4076	2837	5016	3729	5740	4413	6810	5545	8734	7407	2505	3788
	10			3772	1913	3802	2435	4732	3311	5447	3983	6531	5136	8441	6976	2788	4204
	11					3538	2034	4457	2894	5164	3552	6260	4726	8157	6546	3062	4620
	12					3264	1632	4173	2477	4871	3122	5981	4316	7864	6116	3345	5036
ARP1165S	5	328	2498	5713	4779	7195	6323	8425	7519	9558	8624	10864	9975	13412	12479	1912	2814
	6	2987	1986	5328	4202	6836	5785	8052	6960	9173	8047	10498	9425	13028	11902	2283	3372
	7	2645	1473	4944	3625	6477	5247	7679	6401	8789	7471	10132	8876	12643	11325	2655	3929
	8			4559	3058	6118	4717	7306	5850	8404	6903	9766	8336	12259	10757	3027	4478
	9			4166	2490	5751	4187	6925	5300	8011	6335	9391	7795	11865	10190	3407	5027
	10			3772	1913	5383	3649	6543	4741	7617	5759	9016	7246	11471	9613	3788	5584
	11					5024	3119	6170	4190	7233	5191	8649	6705	11087	9045	4160	6133
	12					4657	2581	5788	3631	6839	4614	8275	6156	10693	8469	4540	6691

Output Torque of Spring Return Actuator(inch)

Imperial unit in-lb:

Model	Size	Spring Quantity	Output Torque of Spring Return Actuator(inch)													Spring Return									
			40PSI			60PSI			70PSI			80PSI			90PSI			100PSI			120PSI			0°	90°
			0°	90°	0°	90°	0°	90°	0°	90°	0°	90°	0°	90°	0°	90°	0°	90°	0°	90°					
ARP1970S	5	5737	4419	9796	8313	12134	10749	14249	12811	16342	14859	18685	17273	22888	21405	3230	4664								
	6	5135	3564	9119	7352	11501	9852	13592	11878	15665	13898	18040	16357	22210	20444	3885	5593								
	7	4541	2694	8450	6372	10878	8938	12944	10929	14996	12936	17395	15450	21524	19482	4531	6540								
	8			7736	5402	10245	8032	12287	9987	14319	11975	16758	14535	20846	18521	5186	7478								
	9			7123	4449	9639	7143	11656	9064	13669	11014	16113	13628	20160	17560	5814	8399								
	10			6445	3506	9006	6263	11000	8150	12991	10052	15459	12713	19491	16589	6469	9310								
	11					8374	5358	10343	7209	12314	9100	14823	11788	18814	15637	7124	10248								
	12					7742	4426	9686	6241	11636	8148	14169	10882	18127	14667	7779	11213								
ARP3200S	5	9790	7690	16278	13916	20149	17944	23597	21307	27081	24719	30849	28599	37793	35431	4797	7080								
	6	8887	6429	15298	12479	19217	16577	22629	19886	26083	23254	29898	27204	36795	33966	5779	8452								
	7	8016	5119	14319	11041	18286	15210	21742	18466	22613	21789	28948	25809	35797	32501	6726	9877								
	8			13339	9567	17355	13843	20685	17045	24087	20324	27997	24414	34799	31036	7655	11284								
	9			12359	8111	16423	12475	19726	15625	23089	18860	27047	23019	33709	29571	8673	12744								
	10			11297	6628	15492	11108	18759	14204	22091	17395	26097	21624	32803	28106	9611	14125								
	11					14560	9741	17791	12784	21094	15930	25146	20229	31805	26642	10558	15523								
	12					13672	8459	16823	11364	20096	14465	24196	18833	30807	25177	11505	16904								
ARP4025S	5	11857	8854	20041	16662	25147	21994	29181	25905	33444	30066	38225	35008	46838	43460	6531	9797								
	6	10661	7064	18695	14648	23891	20115	27876	23952	32098	28051	36943	33089	45492	41445	7832	11744								
	7	9464	5265	17349	12625	22635	18226	26571	21990	30752	26028	35662	31162	44146	39422	9133	13700								
	8			16003	10602	21379	16338	25266	20028	29406	24005	34380	29236	42800	37399	10434	15656								
	9			14648	8578	20115	14449	23952	18066	28051	21982	33089	27309	41445	35376	11744	17612								
	10			13302	6555	18858	12561	22647	16104	26706	19958	31808	25382	40100	33352	13045	19567								
	11					17602	10672	21342	14142	25360	17935	30526	23455	38754	31329	14346	21523								
	12							20071	12247	24525	16701	28993	21169	37912	30088	15657	23481								
ARP5826S	5	17326	12947	29278	24353	36683	32086	42613	37837	48843	43917	55829	51138	68398	63473	9523	14284								
	6	15576	10327	27310	21405	34846	29334	40704	34978	46874	40969	53954	48331	66430	60525	11425	17134								
	7	13834	7707	25351	18457	33017	26583	38805	32120	44915	38021	52089	45523	64471	57577	13319	19983								
	8			23382	15509	31180	23832	36896	29261	42947	35073	50214	42715	62502	54629	15222	22833								
	9			21414	12561	29343	21080	34987	26402	40979	32126	48339	39908	60534	51681	17125	25683								
	10			19446	9613	27506	18329	33078	23544	39010	29178	46465	37100	58566	48733	19028	28532								
	11					25677	15577	31179	20685	37051	26230	44599	34293	56606	45785	20921	31382								
	12							29333	17915	35840	24422	42370	30952	55387	43969	22826	34244								
ARP9210S	5	27189	20337	45913	38205	57524	50329	66823	59348	76583	68874	87532	80191	107244	99535	14895	22346								
	6	24446	16227	42828	33581	54644	46014	63831	54864	73498	64251	84594	75787	104158	94912	17877	26816								
	7	21712	12117	39752	28958	51773	41699	60848	50381	70422	59628	81664	71384	101082	90288	20851	31285								
	8			36666	24334	48894	37384	57856	45898	67336	55004	78726	66981	97997	85665	23833	35754								
	9			33590	19711	46022	33068	54873	41415	64260	50381	75796	62578	94921	81042	26807	40223								
	10			30505	15088	43143	28753	51882	36931	61175	45758	72858	58175	91836	76418	29789	44693								
	11					40263	24438	48890	32448	58090	41134	69919	53771	88750	71795	32772	49162								
								45907	27965	55013	36511	66990	49368	85674	67172	35745	53631								

Curves

Output Torque of Double Acting Actuator

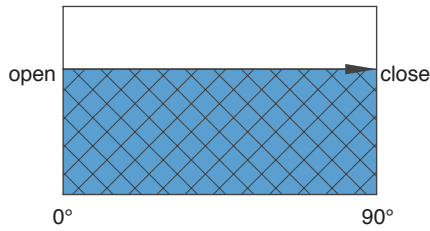

Output Torque of Spring Return Actuator

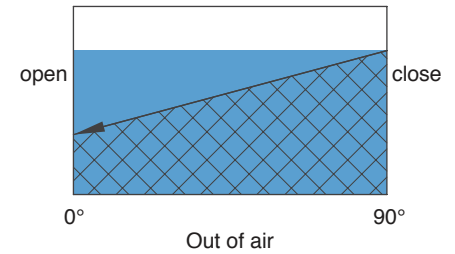
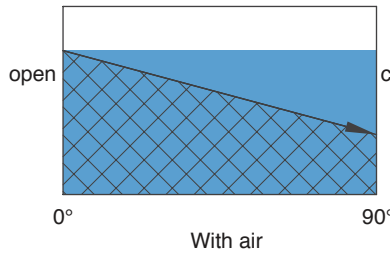

Service Conditions to Consider

1. Operating media:

Dry or lubricated air, or inert gas, or non-corrosive gases that compatible with actuator inner parts and lubricant are available. The media temperature must 10°C lower than ambient temperature at least, and the maximum particle diameter must less than 20μ

2. Air supply pressure:

3 Bar (40 PSI) ~ 8 Bar (120 PSI)

3. Travel adjustment:

Have adjustment range of ±5° for the rotating 90° .

4. Operating temperature:

- Standard: -20°C ~ +80°C
- Low temperature: -40°C ~ +80°C
- High temperature: -15°C ~ +150°C

5. Lubricant:

Use the lubricant that temperature range at -20°C to +80°C. Select special lubricant when the operating condition is low temperature or high temperature.

The Grade of Anticorrosion & Recommended Service Environment

Parts	The Grade of Anticorrosion	
	A	B
Body	Anodise Hardening + Epoxy Polyester Coating	Stainless Steel CF8/CF8M
CAP	Anodise Hardening + Epoxy Polyester Coating	Stainless Steel CF8/CF8M
Drive Shaft	Carbon Steel Nickel Plated	Stainless Steel CF8/CF8M
Piston	Anodise Hardening	Stainless Steel CF8/CF8M
Service Condition	Normal Condition or Low Thickness Acid Environment	High Thickness Acid Environment

Actuator Sizing Guide

Actuation sizing data:

- This reference data are designed to help choose DFS actuator. Before installing the DFS actuator on valve, you must consider the following factors:
- The operating life of this actuator is 3 years or 1 million times. Non-metal parts should be replaced when the actuator is used over half a million times.
- The air pressure for the actuator. The operation torque of valve coupled with safety factor that manufacturer recommended (based on operations).
- The types of actuator, i.e. Double acting actuator and Spring return actuator, and its output torque under certain supply air .

- Actuator's direction of rotation and failure mode (failure open and close)

- It is very important to choose a correct actuator. For example, the stem will be over forced if the actuator is too big. Whereas, there will be not enough torque to operate valve if the actuator is too small. Usually, we consider the required torque to operate valves is from the frictions between metal parts of valve (such as ball and disc) and seals (body). According to the valves' working condition, a lot of factors can influence the torque, such as operating temperature, frequency of operation, management and pressure difference, delivery media (lubricated, dry, muddy).

Below quoted torque characteristics of three different types of 90° travel valves:

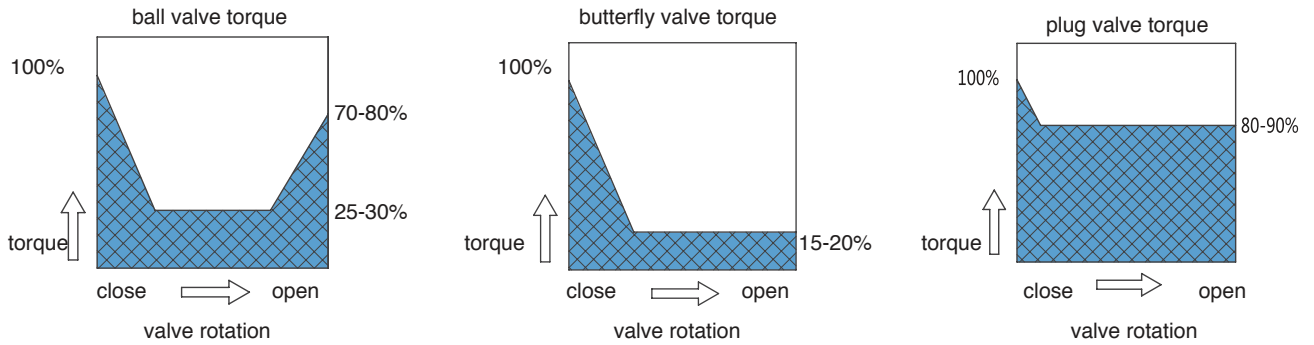

Ball Valve:

Ball valve construction concept is based essentially on a polished ball (include a through port) contained in two seats (upstream and downstream). The ball rotation allows the flow, or stops the flow through the valve. Differential Pressure between upstream and downstream pressures forces the ball against the downstream seat (floating ball). In this case, the valve torque is generated by the friction between ball and seat and also between stem and packing. As shown in the diagram, the highest torque point is when, in presence of pressure, the valve is in the closed position, and passes to the open position (breakaway torque).

Butterfly Valve:

Butterfly valve construction concept is based essentially on a disc fixed on an axis, which in the closed position, is completely contained by the seat. The open position is obtained when, with a rotation, the disc (through its stem) becomes parallel to the flow. On the contrary, the closed position is obtained when the disc is perpendicular to the flow. In the case of the butterfly valve, the torque is generated by the friction between the disc and the seat, by the stem packing and also by the differential pressure that forces on the disc. The highest torque point, as shown in the diagram, is in the closed position, and only after a small rotation it is considerably reduced.

Plug Valve:

The construction principle of the plug valve is basically according to the plug sealed in the conical cock body. There is a channel at a direction of the plug. Along with plug screws in the valve, the valve will open or close. The operating torque is decided by the friction of the valve seat and the plug during the open and close process and is often not influenced by the fluid's pressure. As shown in the picture. The torque is maximal when the valve closes. As without the influence of the pressure, the superior torque will be kept at the following operation.

Double Acting Actuation Guide:

The output torque of rack and pinion pneumatic actuator = piston pressure (air supply pressure) × pitch radius (lever of arm), as Fig.I. Besides, the friction resistance and efficiency are very high. As Fig.II, both of the output torque are linear when CCW or CW. The suggested safety factor for double acting actuators under normal working conditions is 15%-20%.

Example (check the technical data sheet)

- Butterfly valve's output torque = 60NM
- Safety factor (20%) = 60NM × (1 + 20%) = 72NM
- Air supply pressure = 5 bar
- When air supply pressure is 5 Bar, the kind of DFS double acting actuator with output 72NM you need at least is DFS085 for this operation.

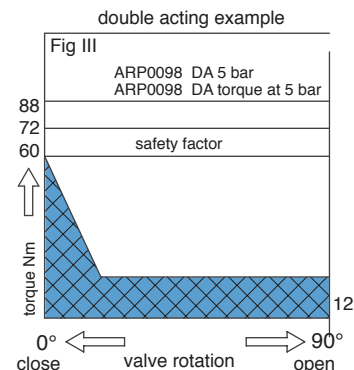
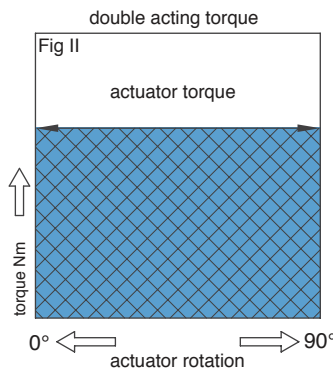
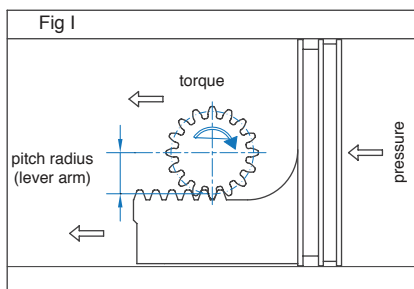

Spring Return Actuation Sizing Guide:

In the application of SR actuator, the output torque is coming from two different process of operation (Fig.1 and Fig.2). According to the travel position (0° and 90°), every operation gets two different torque. SR actuator's output torque = pressure (air or spring work on the piston) × pitch radius (lever of arm).

The first situation (Fig.1): output torque is coming from air supply pressure inside the Port 2 and squeezing the spring. It is known as "air travel output torque". In this situation, air supply pressure pressurized from 0° position to 90° position. As squeeze spring have a reaction force, torque is decreasing gradually from the starting 0° position to 90° position (Fig. A).

The second situation (Fig.2): the output torque is coming from the spring return forcing work on the piston when out of air. It is known as "spring travel output torque". In this situation, because of the comeback of spring, torque is decreasing gradually from the starting 90° position to 0° position (Fig. B).

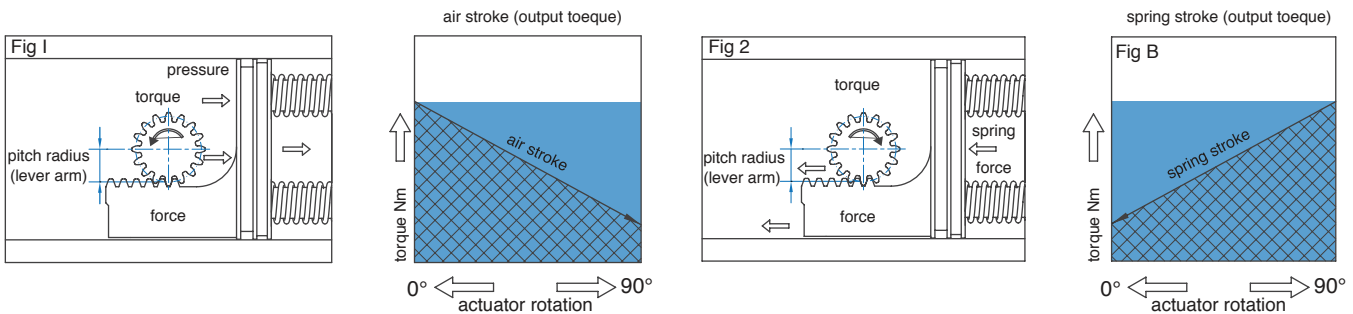

In a word, ARP actuator is designed base on the fact that two situations get one balanced torque, i.e. the numbers of springs are the same as air supply pressure readings each side (4 bar, 4 springs each side), as shown in Fig. C. There are possibilities to get an unbalanced torque in every situation, as shown in Fig. D, by changing the number of springs and air supply pressure (such as six springs each side and 5.5 bar air supply pressure, and vice versa).

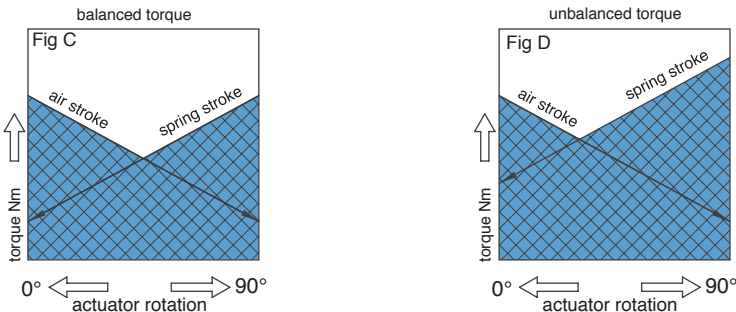

In the application of SR actuator, there are two situations: out of air open or out of air close. The suggested safety factor for spring return actuators under normal working conditions is 20%-25%.

Example (check the technical data sheet):

- Springs closed (out of air)
- Ball valve's output torque = 100NM
- Safety factor (20%) = $100 \times (1 + 20\%) = 120\text{NM}$
- Air supply pressure = 5 Bar

The selected actuator is DFS145, therefore it gets the following data (Fig.E):

- Spring stroke 0° = 131NM
- Spring stroke 90° = 205NM
- Air stroke 0° = 289NM
- Air stroke 90° = 215NM

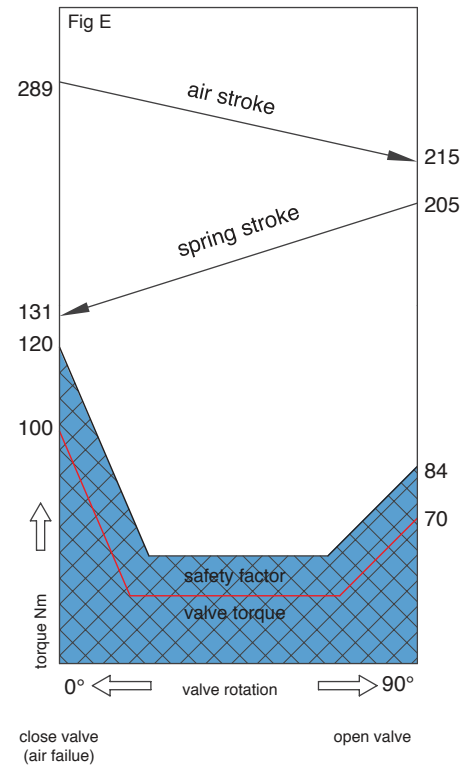

Trouble Phenomena	Checking Item	Solution
Pneumatic Valve Does Not Act.	1.- Does the solenoid work normally 2.- Is the circuit burned 3.- Is the mandrel of the solenoid blocked by impurity	1.- Replace the solenoid 2.- Replace the circuit 3.- Remove the impurity
	With air supplying the pneumatic actuator, are the o-rings or the cylinder broken?	Replace the broken o-rings and cylinder body
	Is impurity blocking the valve	Clean out the impurity, replace the broken parts
	Is the handle of the manual equipment at the manual state?	Put the handle to the pneumatic state
Acting Slowly	is the air supply pressure insufficient?	Improve the air pressure
	Is the output torque of pneumatic actuator not enough?	Select a bigger model of the pneumatic actuator
	Is the valve stem or other parts assembled too tightened?	Reassemble and adjust the valve
	Is the air supply pipe blocked making the air flux too small?	Clean out the block, replace the filter stem
The Feedback Has No Signal	Is the power shorted out or stopped?	Check the circuitry
	Is the cam of the feedback in the incorrect position?	Adjust the cam to the correct position
	Is the jiggle on-off broken?	Replace the jiggle on-off





Features

- ① High-strength, high-output torque.
- ① Built in one body, IP67 solid weatherproof sealing.
- ① Mounting base standard, ISO5 211.
- ① Patented pneumatic-hand lift safety device.
- ① Self lubricated bearing for worm & worm gear .
- ① WCB body surface treated by phosphating, epoxy & polyester coating.
- ① Yellow & black color

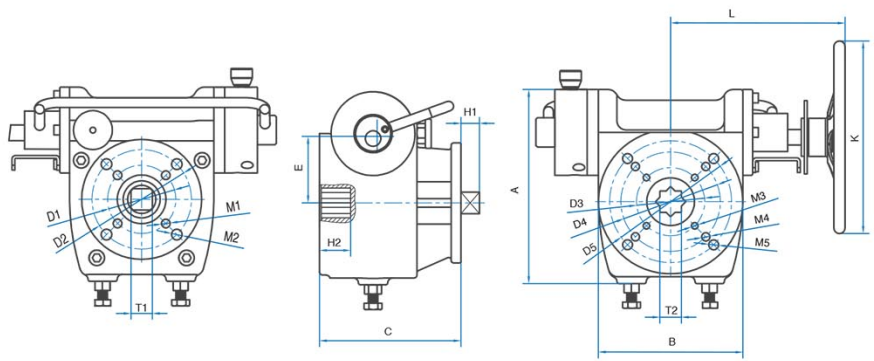

Model	A	B	C	D1	D2	D3.D4.D5	E	L	M1	M2	T1	T2	H1	H2	K	J	Applicable actuators	Input torque	Output torque
AMO0150	120	100	104	φ50	φ70	F05.F07	44.5	114	φ7	4-φ9	□ 17	□ 17	14	25	φ160	1/4"NPT	DFS032~085	17N.m	150N.m
AMO0200	120	100	104	φ50	φ70	F05.F07	44.5	120	φ7	4-φ9	□ 17	□ 17	14	25	φ200	1/4"NPT	DFS075~100	22N.m	200N.m
AMO0600	192	148	145	φ70	φ102	F07.F10.F12	71	175	φ9	4-φ11	□ 22	□ 27	19	30	φ200	1/4"NPT	DFS100~145	42N.m	600N.m
AMO0900	192	148	145	φ70	φ102	F07.F10.F12	71	178	φ9	4-φ11	□ 27	□ 27	19	30	φ250	1/4"NPT	DFS145~160	70N.m	900N.m
AMO1200	192	148	145	φ70	φ102	F07.F10.F12	71	181	φ9	4-φ11	□ 27	□ 27	19	30	φ300	1/4"NPT	DFS145~180	96N.m	1200N.m
AMO1600	260	196	191.5	φ102	φ125	F10.F12	107.5	268	φ11	4-φ13	□ 36	□ 36	34	40	φ350	1/4"NPT	DFS160~200	80N.m	1600N.m
AMO2000	260	196	191.5	φ102	φ125	F10.F12	107.5	272	φ11	4-φ13	□ 36	□ 36	34	40	400	1/4"NPT	DFS200~240	100N.m	2000N.m
AMO3300	334	255	181	φ165	-	F12.F16	123	272	φ22	-	□ 46	□ 46	45	176	φ600	1/4"NPT	DFS240~265	190N.m	3300N.m
AMO4000	334	255	181	φ165	-	F12.F16	123	275	φ22	-	□ 46	□ 46	45	176	φ700	1/4"NPT	DFS265~300	230N.m	4000N.m
AMO7000	389	297	249	φ165	φ254	F16.F25	156	418	φ22	8-φ13	□ 46/55	□ 46	45	196	φ500	1/2"NPT	DFS350~400	110N.m	7000N.m

PART LIST

16

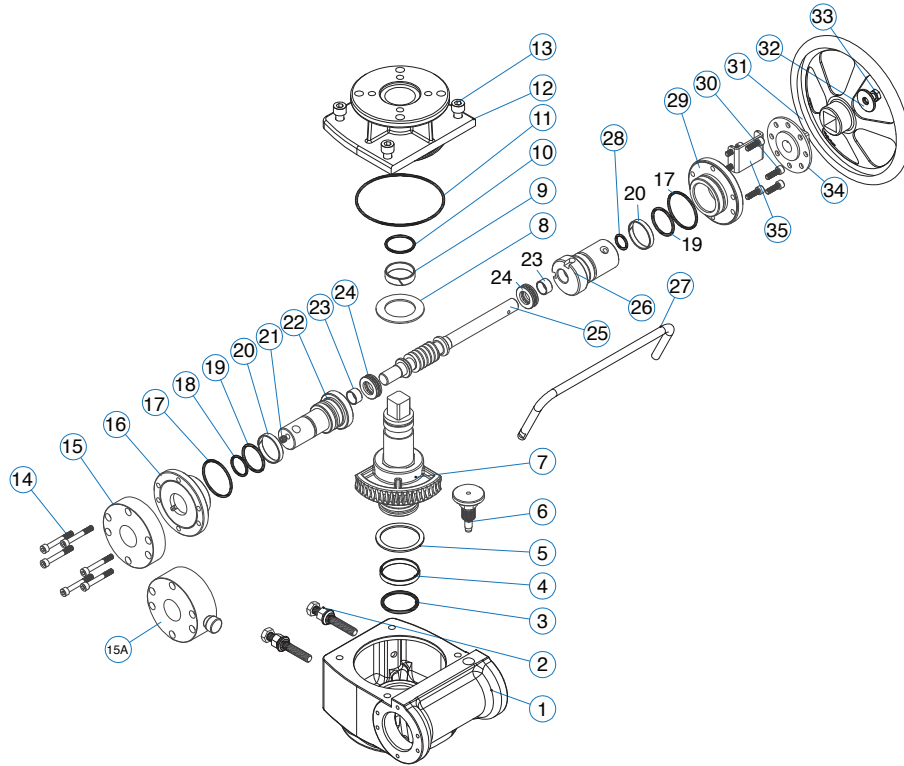

No.	Part Destination	QTY.	Material
1	Body	1	WCB
2	Adjust Bolt	2	304
3	O Ring	1	NBR
4	Bearing	1	POM
5	Bearing	1	POM
6	Positioning unit	1	45
7	Shaft	1	45
8	Washer	1	POM
9	Bearing	1	POM
10	O Ring	1	NBR
11	O Ring	1	NBR
12	Cap	1	WCB
13	Screw	4	304
14	Screw	6	304
15	Cap	1	45
*15A	Air shift valve	1	45
*16	Cap	1	AL380
17	O Ring	2	NBR

No.	Part Destination	QTY.	Material
18	O Ring	1	NBR
19	O Ring	2	NBR
20	Eccentric axle bearing	2	POM
21	Bolt	1	304
22	Eccentric half axle	1	45
23	Bearing	2	Cu
24	Thrust ball bearing	2	Steel
25	Worm shaft	1	45
26	Eccentric half axle	1	45
27	Shift handle	1	45
28	O Ring	1	NBR
29	Cap	1	45
30	Screw	6	304
31	Hand wheel	1	20
32	Washer	1	20
33	Bolt	1	304
*34	Lock disc	1	45
*35	Lock bracket	1	45

HOW TO ORDER

Actuator Model	Type	ISO 5211
ARP0006		F049
ARP0010		F04059
ARP0017		F0517
ARP0031		F0517
ARP0063	D: Double Acting	F050722
ARP0098		F050722
ARP0142		F071022
ARP0236		F071022
ARP0300	S: Spring Return	F1036
ARP0462		F101236
ARP0625		F101236
ARP0848		F101436
ARP1165		F101436
ARP1970		F121646
ARP3200		F1646
ARP4025		F1646
ARP5876		F2555
DFS9210		F2555





www.tfvusao.com

contact@tfvusao.com

Call free from USA and CANADA
 1-86-TFV-USAO (838-8726)

